

# ENGINE ELECTRICAL SYSTEM

Wiring System

## 3. 6-CYLINDER ENGINE MODEL S903482A2105

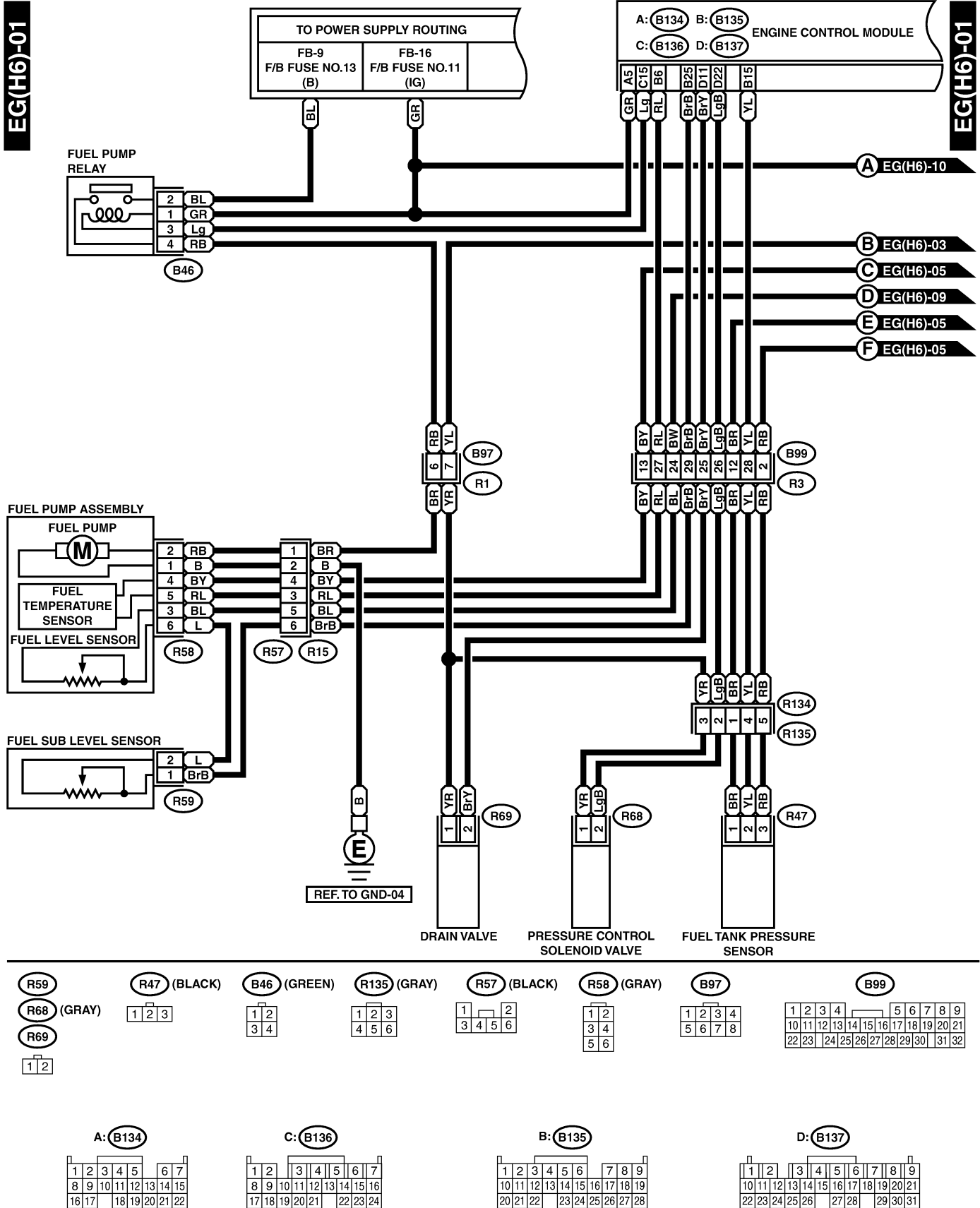

# ENGINE ELECTRICAL SYSTEM

Wiring System

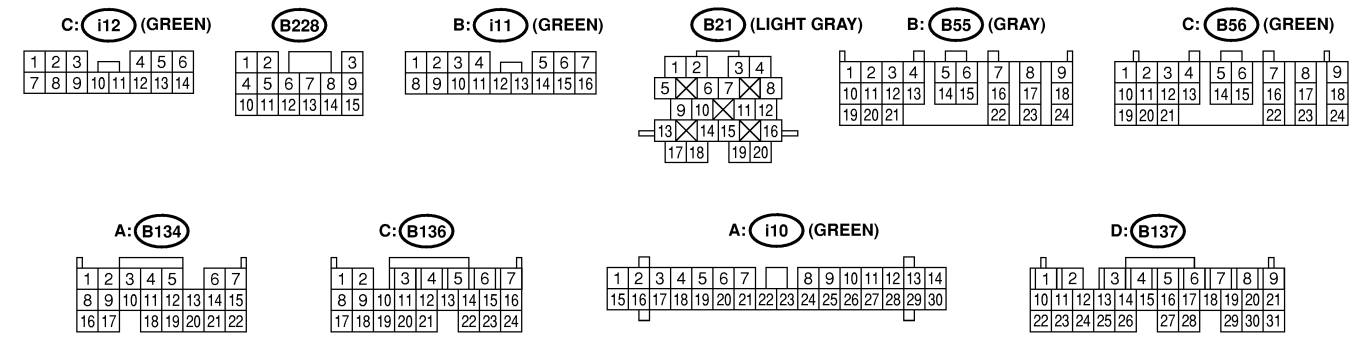
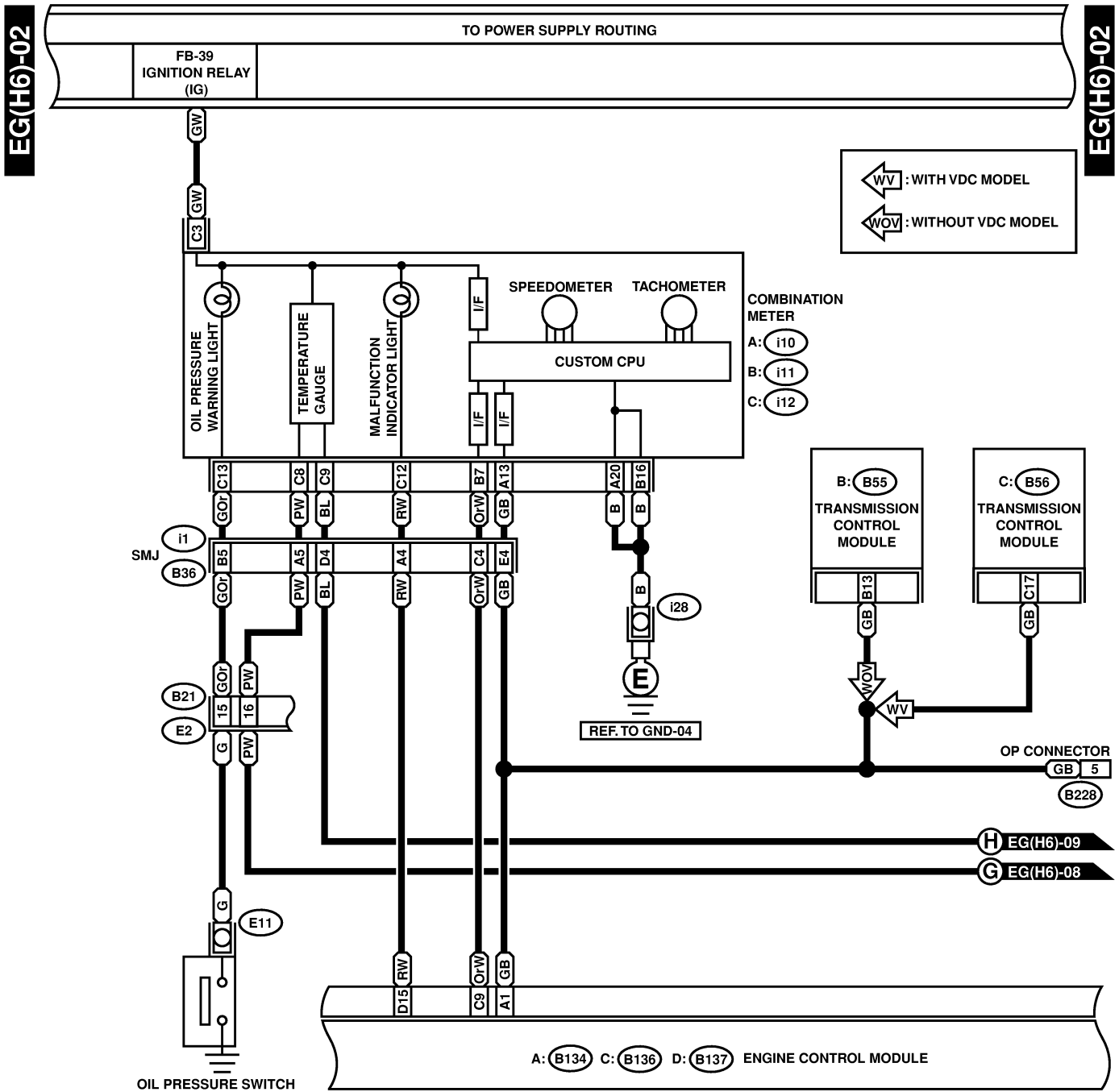

# ENGINE ELECTRICAL SYSTEM

Wiring System

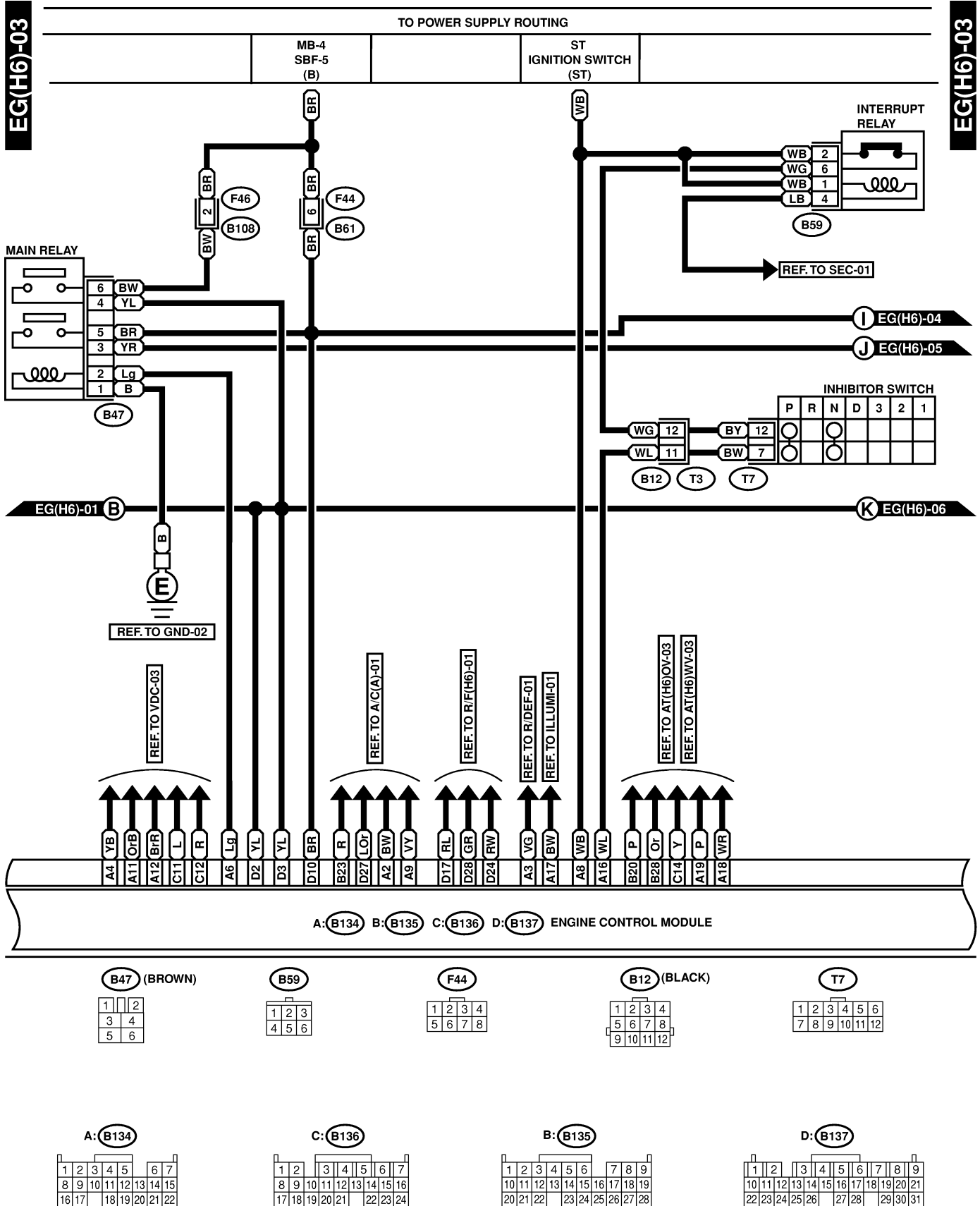

# ENGINE ELECTRICAL SYSTEM

Wiring System

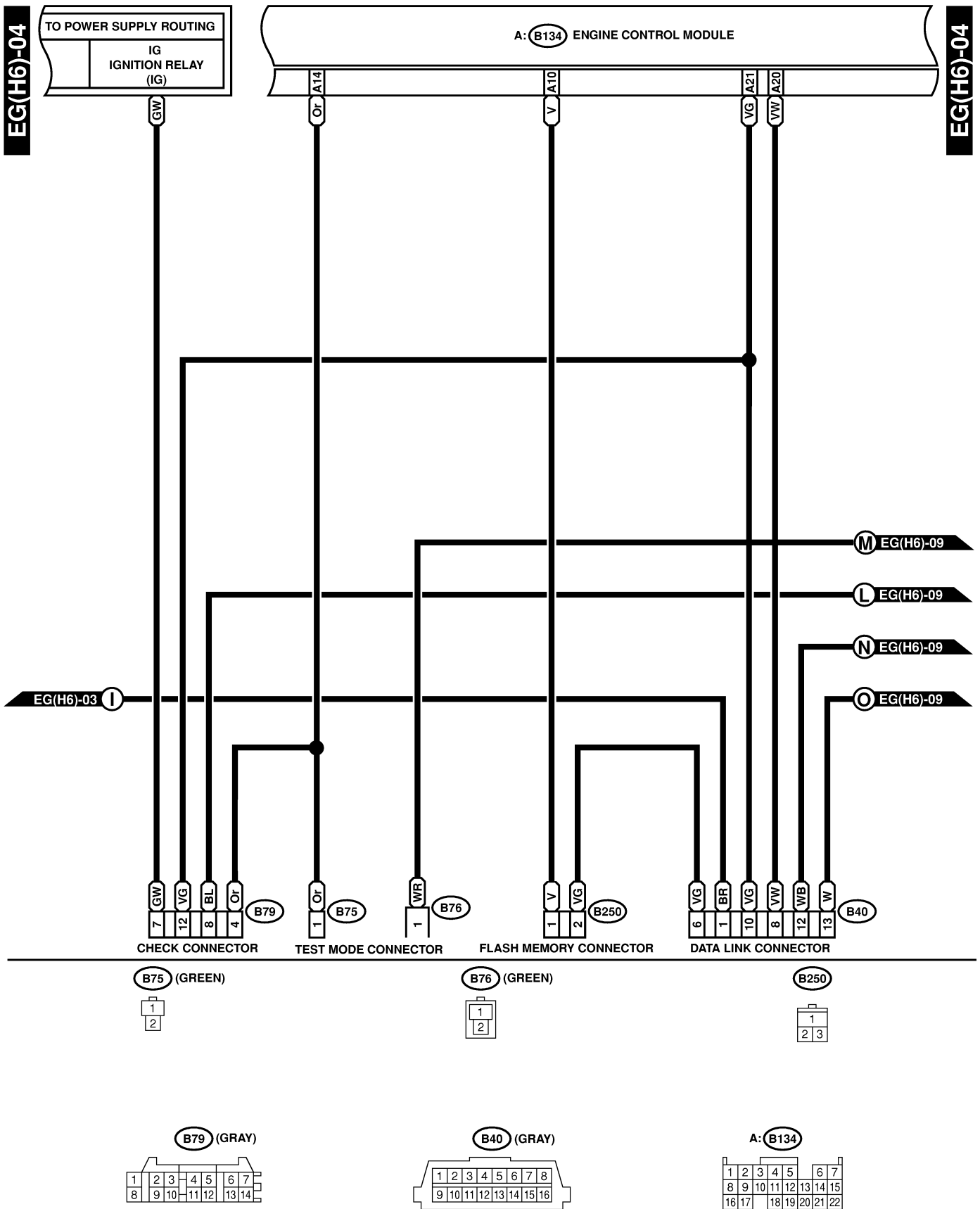

BU10-25D

# ENGINE ELECTRICAL SYSTEM

Wiring System

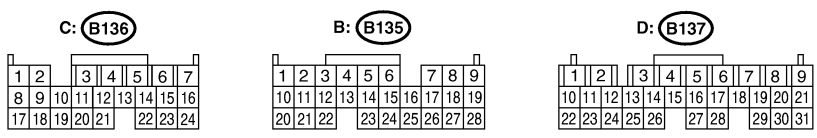
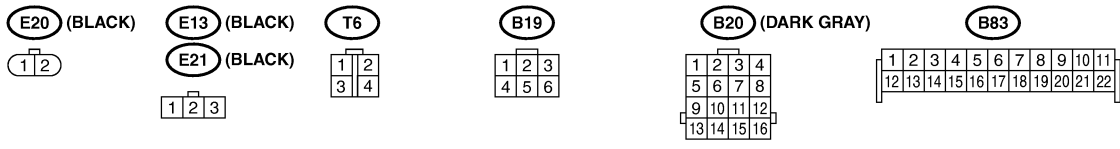
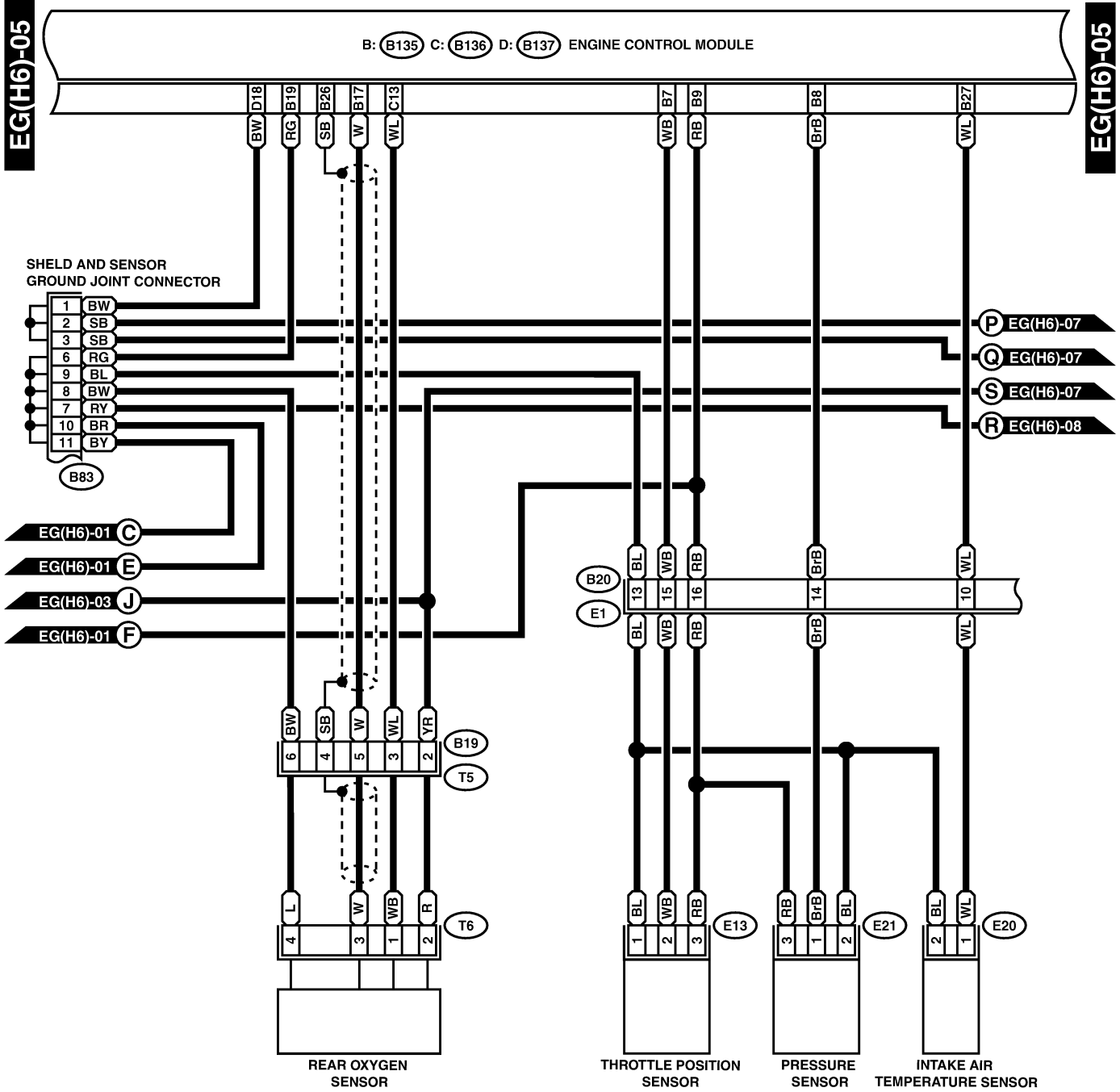

# ENGINE ELECTRICAL SYSTEM

Wiring System

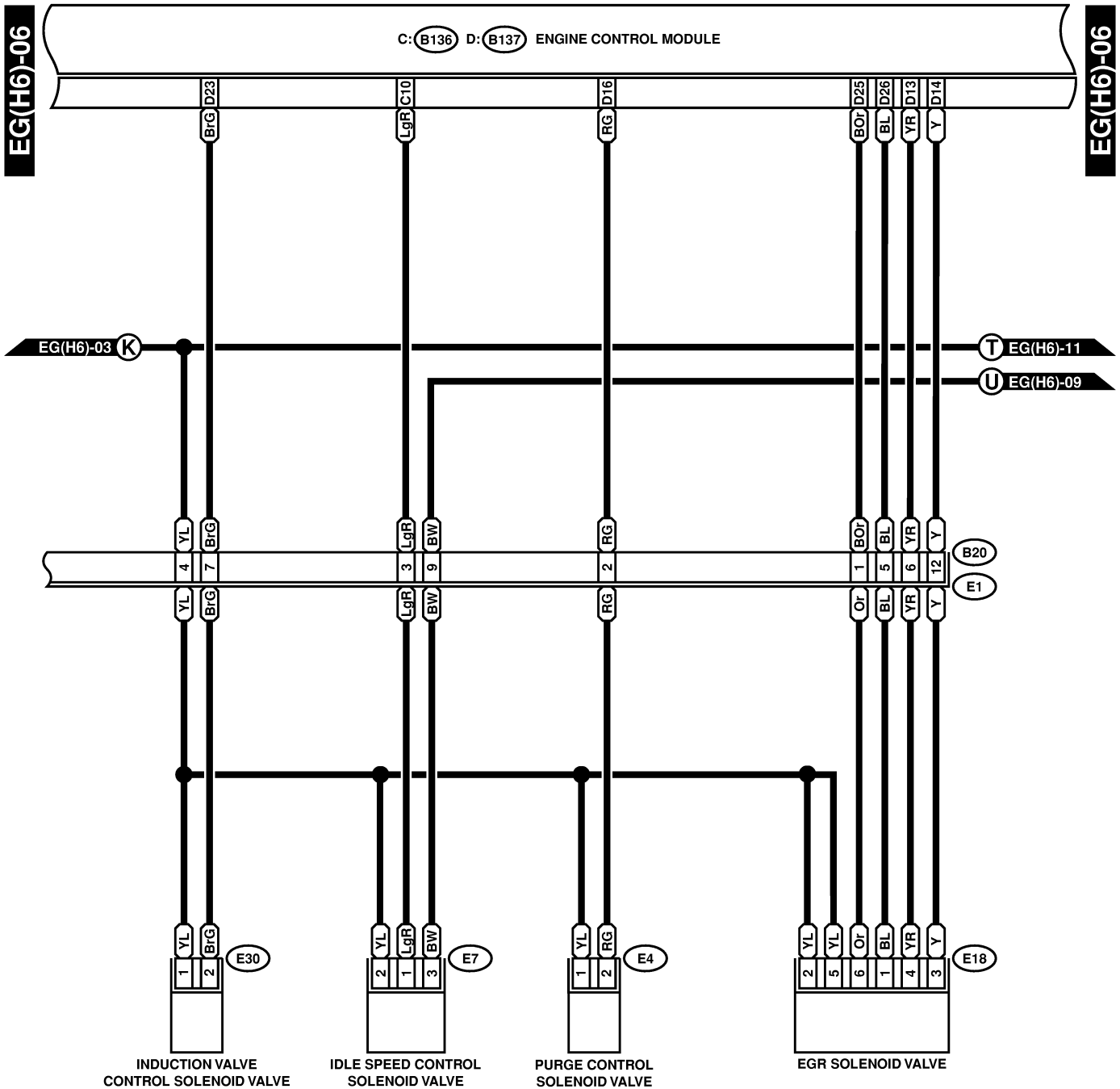

**E30** (BROWN)



**E4** (BLACK)



**E7** (GRAY)



**E18** (GRAY)



**B20** (DARK GRAY)

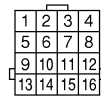

C: **B136**

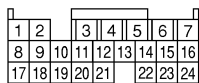

D: **B137**

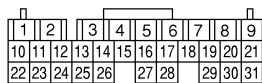

# ENGINE ELECTRICAL SYSTEM

Wiring System

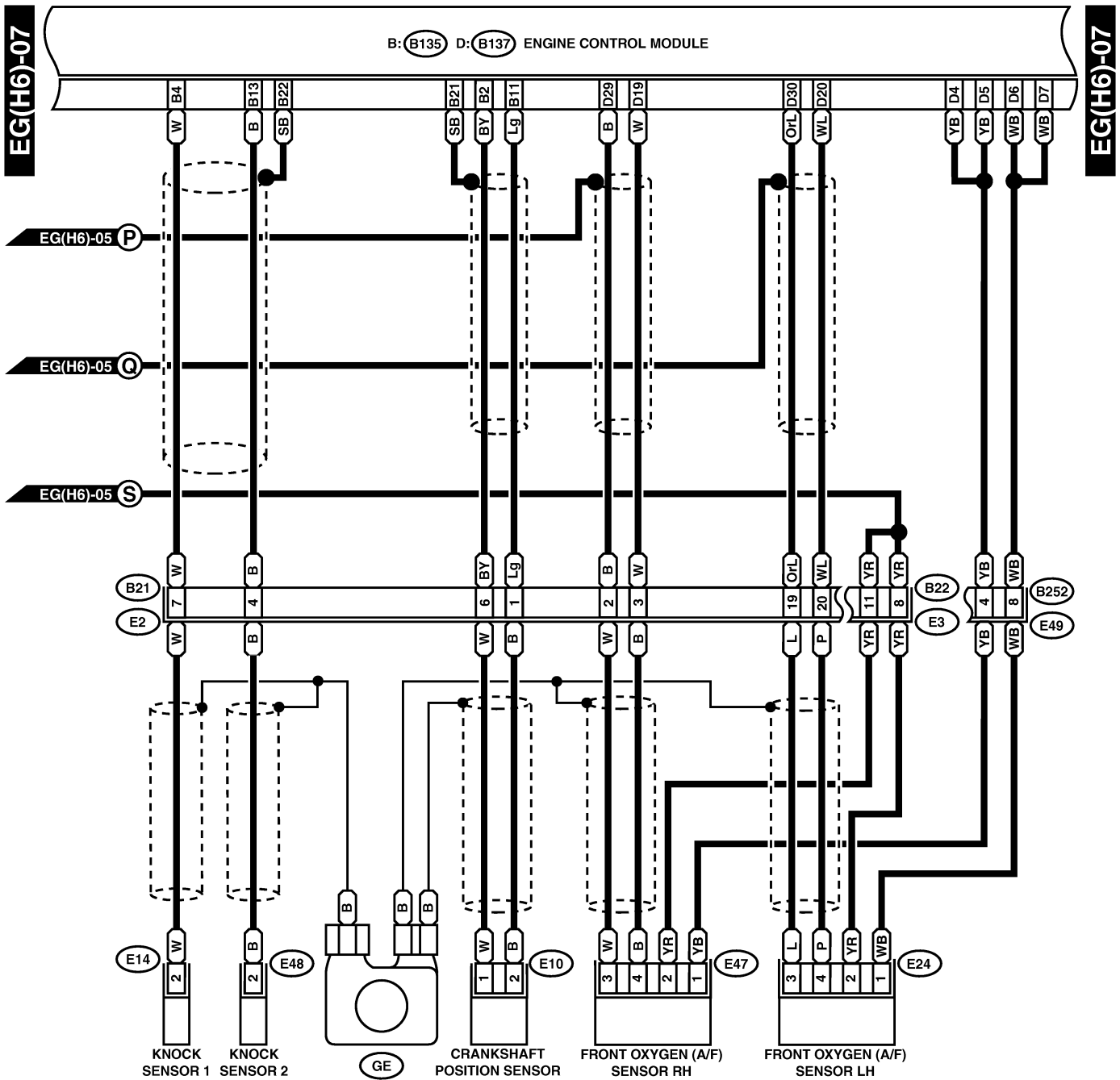

E14 (BLUE)

E10 (GRAY)

E24 (DARK GRAY)

B252 (DARK GRAY)

B22 (BROWN)

B21 (LIGHT GRAY)

E48 (BLUE)

1 2

E47 (DARK GRAY)

1	2	3	4
5	6	7	8

1	2	3	4
5	6	7	8
9	10	11	12
13	14	15	16

1	2	3	4
5	6	7	8
9	10	11	12
13	14	15	16
17	18	19	20

1	2
---	---

1	2
3	4

B: (B135)

D: (B137)

1	2	3	4	5	6	7	8	9	
10	11	12	13	14	15	16	17	18	19
20	21	22	23	24	25	26	27	28	

1	2	3	4	5	6	7	8	9			
10	11	12	13	14	15	16	17	18	19	20	21
22	23	24	25	26	27	28	29	30	31		

# ENGINE ELECTRICAL SYSTEM

Wiring System

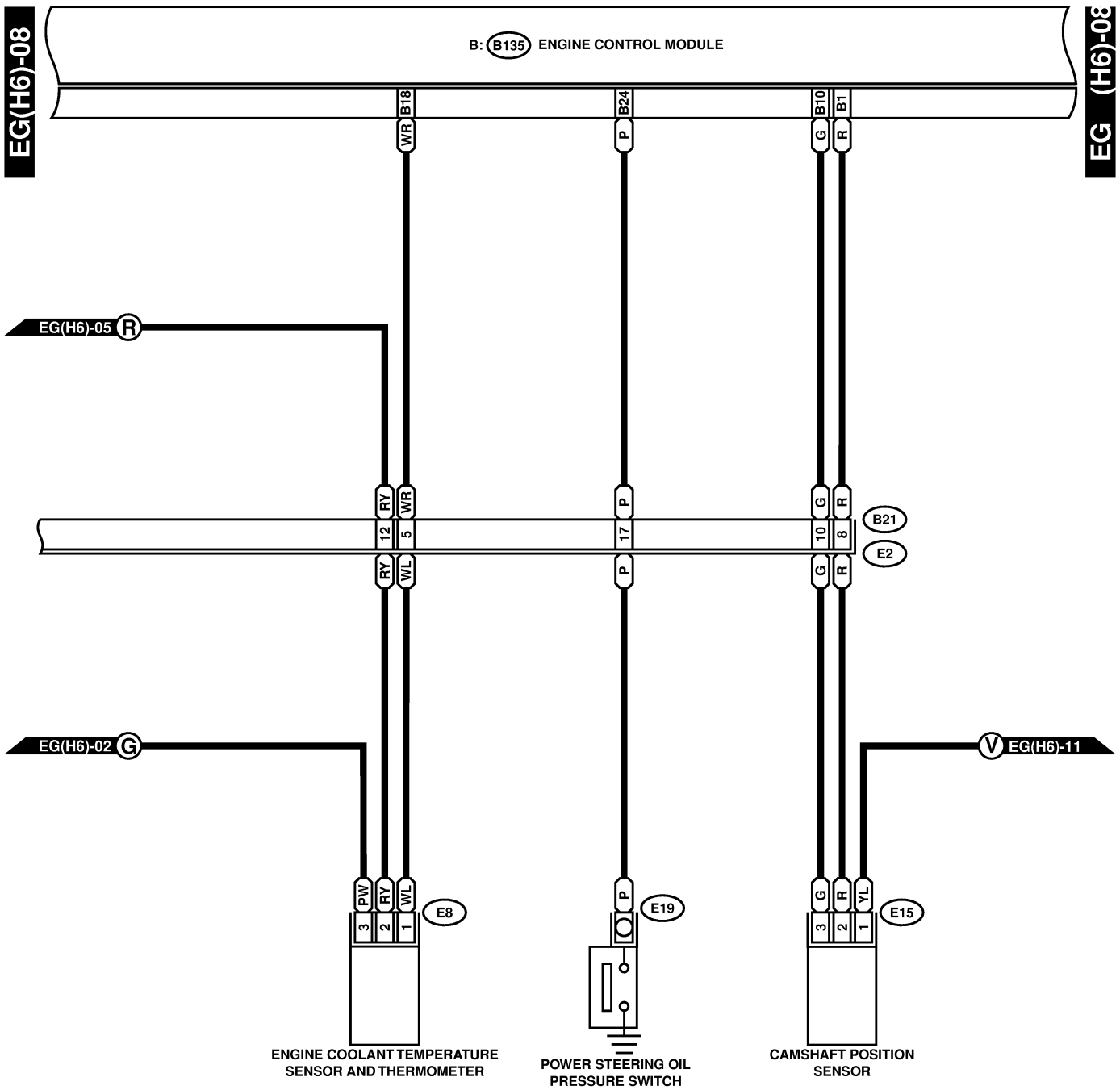

E15 (GRAY)



E8 (LIGHT GRAY)



B21 (LIGHT GRAY)

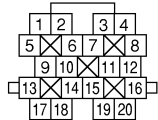

B: B135





# ENGINE ELECTRICAL SYSTEM

Wiring System

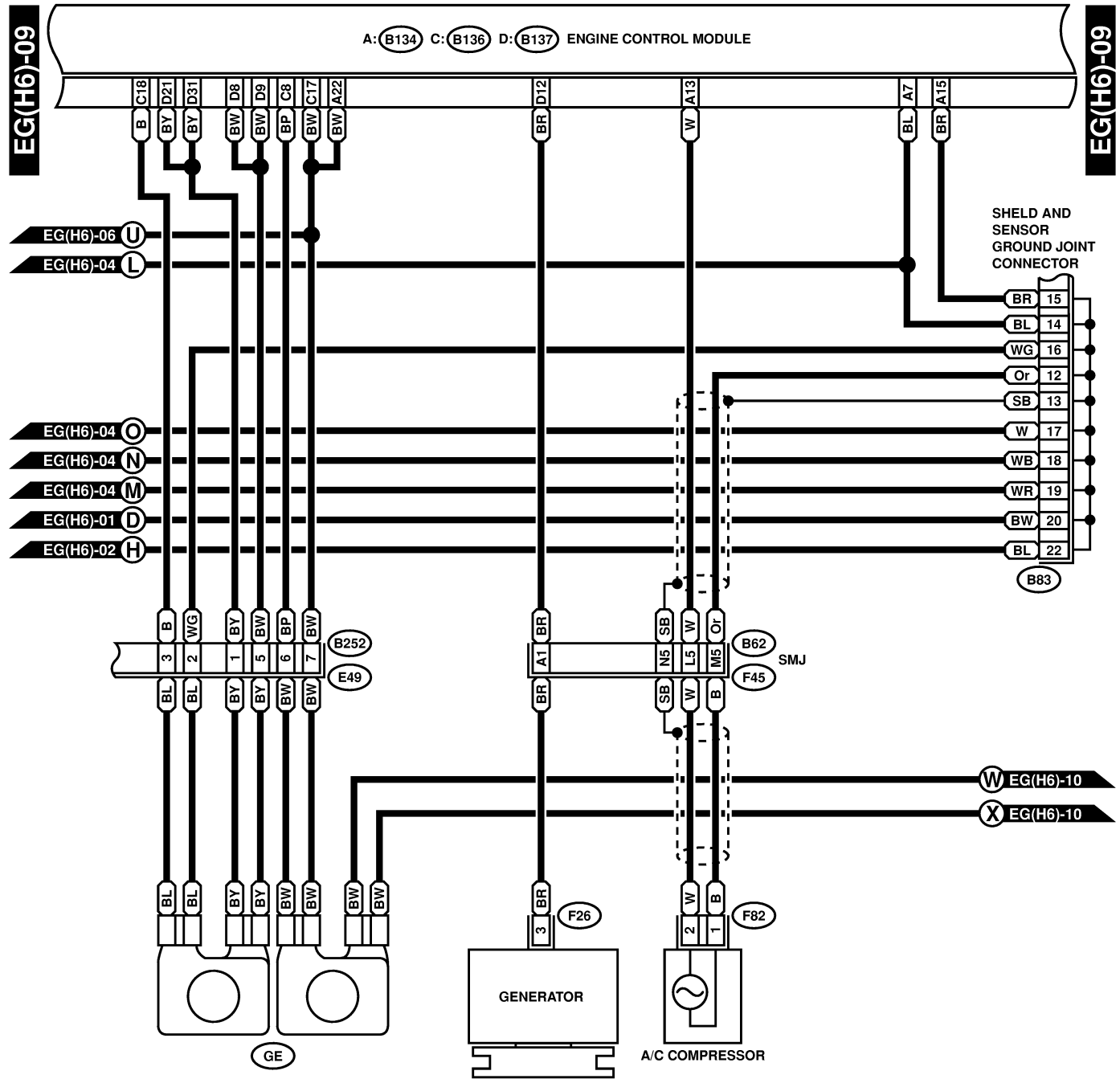

E26 (GREEN)

F82 (BLACK)



B252 (DARK GRAY)

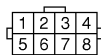

B83

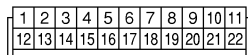

A: B134

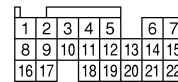

C: B136

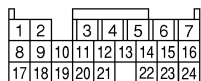

D: B137

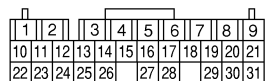

# ENGINE ELECTRICAL SYSTEM

Wiring System

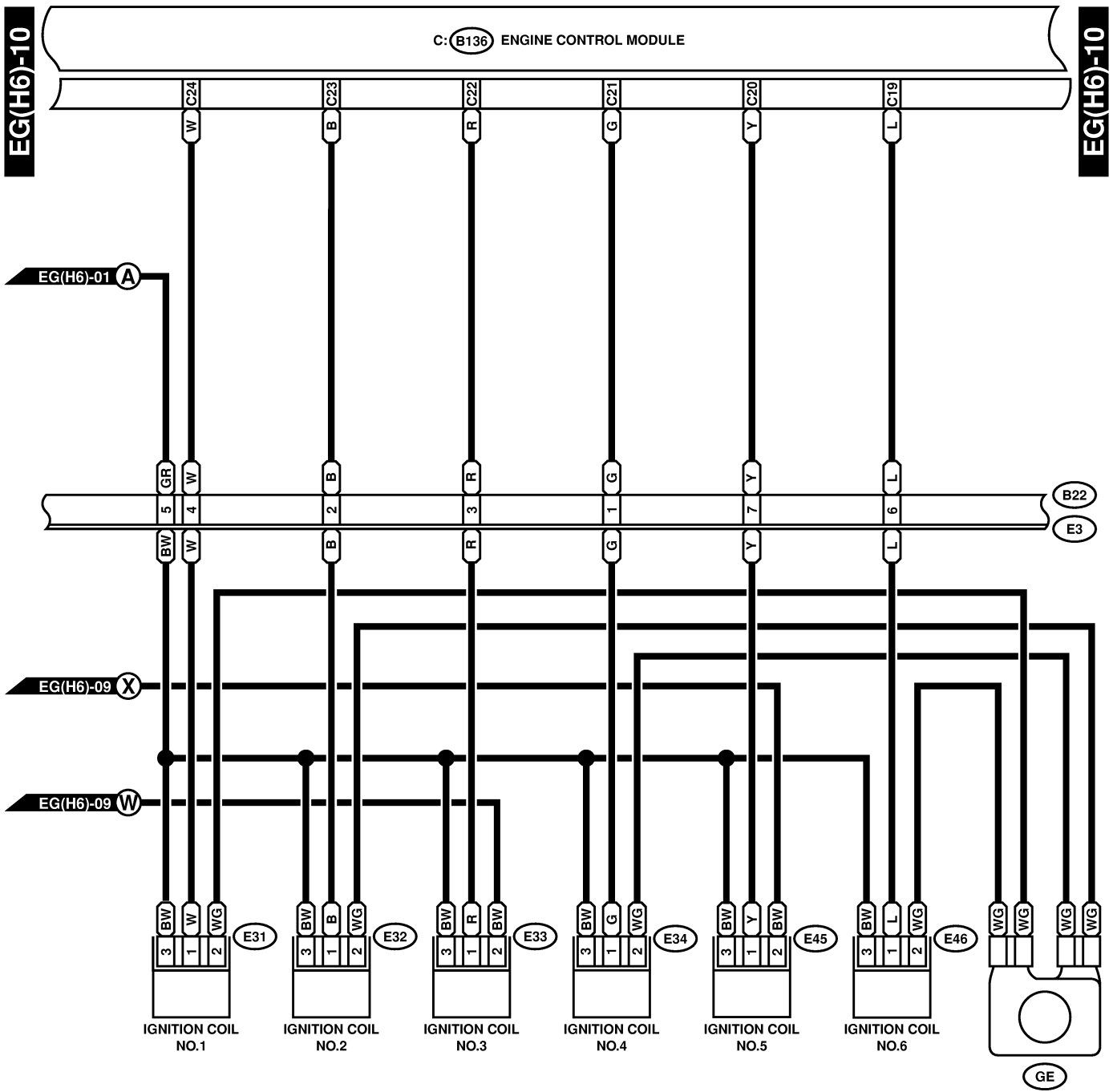

- (BLACK) **E31**   **E34**
  - (BLACK) **E32**   **E45** (BLACK)
  - E33**   **E46** (BLACK)
- |   |
|---|
| 1 |
| 2 |
| 3 |

**B22** (BROWN)

1	2	3	4
5	6	7	8
9	10	11	12
13	14	15	16

**C: (B136)**

1	2	3	4	5	6	7
8	9	10	11	12	13	14
15	16	17	18	19	20	21
22	23	24				

# ENGINE ELECTRICAL SYSTEM

Wiring System

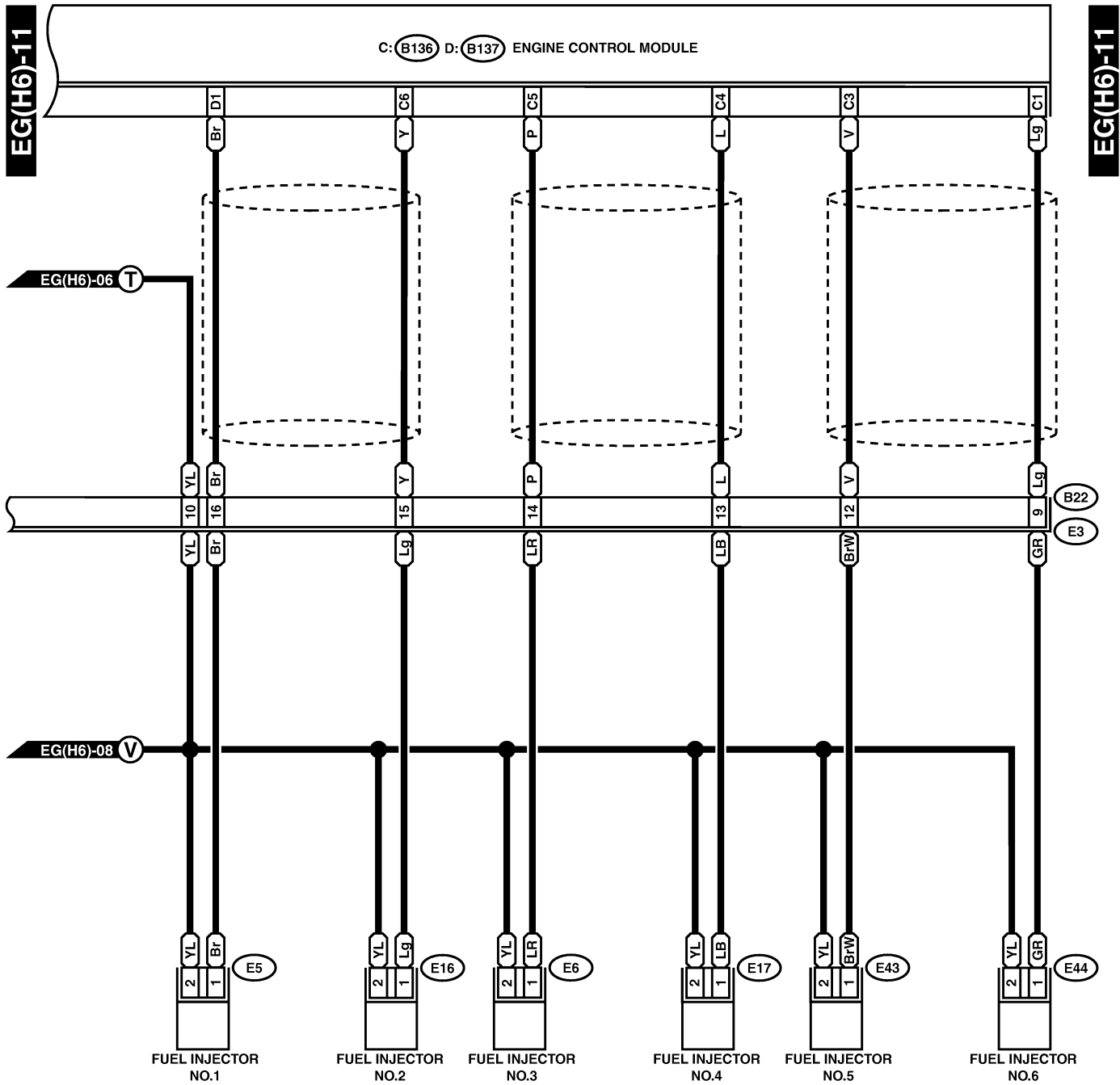

- (GRAY) E5 (GRAY) E17
- (GRAY) E6 (GRAY) E43
- (GRAY) E16 (GRAY) E44



B22 (BROWN)



C: B136

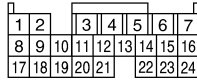

D: B137

